

NOSE LANDING GEAR - CLEANING/PAINTING

1. General

A. This procedure provides cleaning and painting instructions for nose landing gear components. These components are constructed of aluminum and steel alloy. The following anticorrosion treatment processes are applied at time of manufacture:

(1) Aluminum Alloy Parts:

- (a) Chemically degreased.
- (b) Chemically film-conversion-coated.
- (c) Epoxy primed.
- (d) Top coated with Polyurethane paint.

(2) Steel Alloy Parts:

- (a) Chemically degreased.
- (b) Epoxy primed.
- (c) Top coated with Polyurethane paint or white polyester powder coat.

B. For an illustration of nose landing gear construction materials, refer to Figure 701.

2. Tools, Equipment and Materials

A. Refer to Landing Gear - General for a list of required tools, equipment and materials.

NOTE: Follow the directions of the manufacturer or supplier for storing, mixing and applying spray wash primers, brush chem-film primers, epoxy primers, and topcoats.

3. Refinishing High Stressed Steel Shot Peened Surfaces

WARNING: The outer surface of the nose gear drag link spring is shot peened during final manufacture and prior to the application of protective coatings. The shot peened surface is thin and must not be disturbed or damaged. Do not use chemical strippers of any kind to remove paint from shot peened surfaces. Chemical strippers have acids that may cause hydrogen embrittlement. Also, do not sand or sand blast the nose gear drag link spring.

A. Refinishing minor nicks and scratches on the nose gear drag link spring.

- (1) Using a soft, hand wire brush or ScotchBrite pad (no power tools), gently remove loose paint, scale, and rust. Use good judgement to prevent damaging the shot peened surface. For large areas, the preferred method is media stripping. This includes glass bead, plastic bead, or wheat starch.
- (2) If the primer is damaged in an area larger than the size of a dime, the area should be hand solvent cleaned with an approved solvent and reprimed with epoxy primer.
- (3) Spot paint the damaged areas with Polyurethane paint.

B. Complete refinishing of the nose gear drag link spring.

- (1) Remove the spring from the airplane.
- (2) Remove all paint by media stripping using glass bead, plastic bead, or wheat starch.
- (3) Remove all media and loose particles with compressed air, clean with an approved solvent and prime with epoxy primer.
- (4) Apply Polyurethane topcoat.

4. Refinishing Steel, and Aluminum Components

A. Refinishing of minor nicks and scratches.

- (1) Feather sand edges of finish around the effected area with 320 grit sandpaper, followed by 400 grit. Avoid sanding through the primer if possible.
- (2) For steel parts, if primer is damaged in an area larger than the size of a dime, the area should be hand solvent cleaned with an approved solvent then reprimed with a epoxy primer.
- (3) For aluminum parts, if primer is damaged in an area larger than the size of a dime, the area should be hand solvent cleaned with an approved solvent, then apply a spray wash primer or brush chem-film primer.
 - (a) After spray wash primer or brush chem-film primer has dried for at least 30 minutes, apply epoxy primer.

(4) Spot paint damaged areas with Polyurethane paint.

B. Complete refinishing.

(1) Degrease and remove sealants and heavy soil with approved solvents.

(2) Strip original finish following recommendations of stripper manufacturer.

CAUTION: Do not allow stripper to come in contact with the nose gear drag link spring. Wear protective clothing and avoid contact with skin. Use of chemicals requires good ventilation and good fire safety practices.

(3) Use wire brush, ScotchBrite or fine aluminum oxide paper to remove any remaining loose paint, scale, and rust.

(4) Hand solvent clean with an approved solvent.

(5) Apply epoxy primer to steel parts. Apply spray wash primer, or brush chem-film to aluminum parts.

(6) Apply epoxy primer to aluminum parts.

(7) Apply Polyurethane topcoat.

Figure 701 : Sheet 1 : Nose Landing Gear Construction Materials

A22379

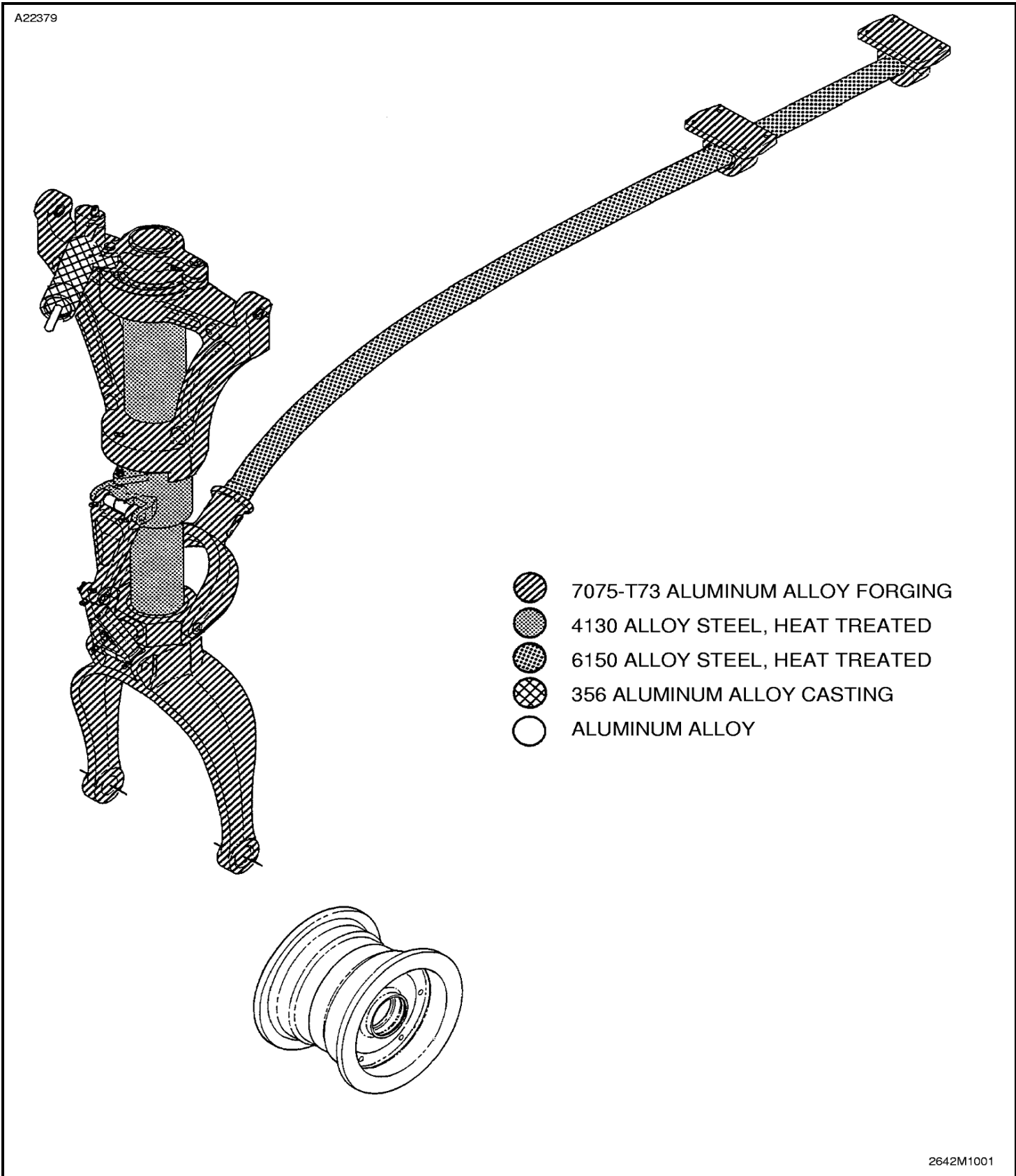

2642M1001